



The SINE33i SI series of AC-AC Static Inverters fully complies with BS EN 50171:2001. All components can be accessed from the front so there is no need to leave space at the back or sides of the unit for ventilation or maintenance.

The inverter's output voltage is 400VAC three phase and neutral, therefore standard mains luminaires can be used without any modification; this also allows the system to be integrated into existing lighting circuits. The inverter has been designed in such a way that unbalanced loads are not a problem.

Systems have been designed and sized to make maximum use of the batteries; this means you get the best possible value for your money.

System Operation

- **Mains Available:** The mains power supplies the three phase battery charger which converts the AC into DC and charges the battery. The mains power also supplies power to the load via the Static Switch Changeover, this is the reserve or bypass path and is used with maintained systems. The inverter is normally on when mains is available (active standby).
- **Mains Fail:** The Static Switch transfers the load to the inverter. The inverter will supply a Sinewave output for the rated duration, once this point is reached the inverter will turn off automatically to protect the batteries.

Specifications

Enclosure

- High quality steel enclosure finished in RAL7032 powder coating
- Front access enclosure – all parts including batteries can be replaced or measured via the front door so there is no need to leave space at the back or sides of the unit for ventilation or maintenance
- Bottom cable entry with removable gland plate for simple installation
- IP rating for standard enclosures is IP20 (higher IP ratings available)
- Plinth allows good manoeuvrability with forklift or pallet truck during installation, cabinets are only 720mm wide so fitting through standard doors is no problem
- Key locked front door

System Operation

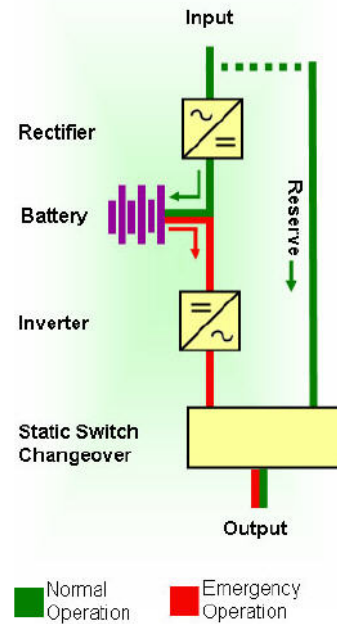

Dimensions

Type	H	W	D
D(IP20)	1400	720	800
SD(IP20)	1800	820	620
E(IP20)	1400	1440	800

Sizes subject to change without notice

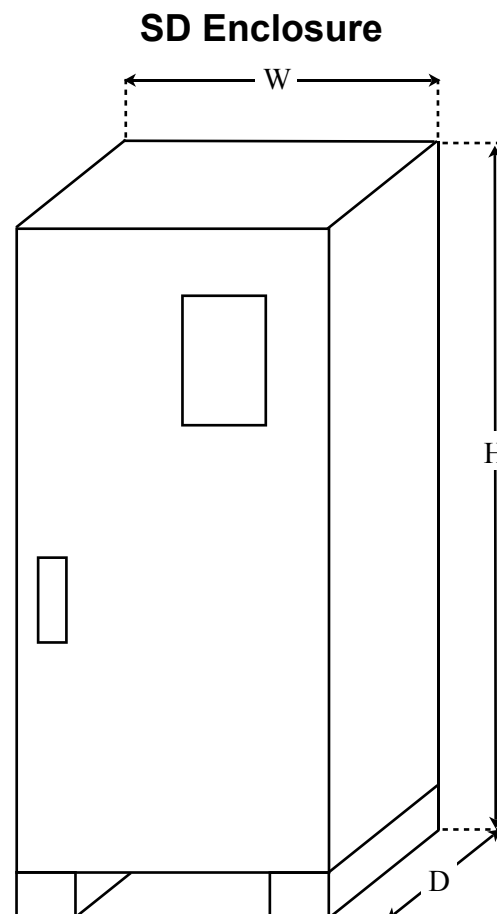
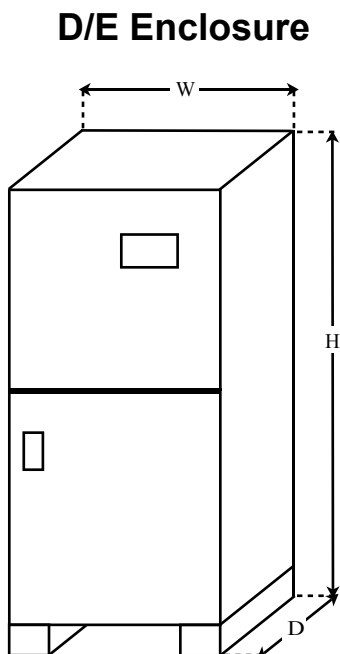

Battery Charger

- Three phase input
- Full recharge within 24 hours, 80% capacity within 12 hours in compliance with BS EN 50171:2001
- Temperature compensation – battery charge voltage adjusted (+-3mV/degree C/cell) in accordance with battery manufacturers specification to optimise battery life
- Constant voltage, current limited (C/10).
- Protection against battery over-voltage, input mains low and mains surges e.g. Surges caused by lightning.

Battery

- Valve Regulated Lead Acid (VRLA)
- 10 Year life at 20 Degrees C
- Complies with BS EN 60896-2

Inverter

- High Frequency pulse width modulation (PWM) IGBT inverter
- High quality sinewave output
- Galvanic isolation
- High efficiency
- Reliable, proven design

Static Switch Changeover

- Fully rated thyristor modules

Load circuit

- Single output load circuit - maintained or non-maintained (default maintained)
- Multiple output distribution option available

Remote Monitoring circuits

- Volt free contacts - Common Alarm, Mains Fail, Battery U/ V, Overload

Low Battery Voltage Disconnect

- This circuit operates after the inverter has turned off due to a low battery shutdown and prevents the system from discharging the batteries during extended periods of mains supply failure.

Manual Battery test

- A ten minute test and a deep test are accessible via the display, the system will simulate a mains failure and discharge the battery for the predetermined time

Display

- Consists of 4 x 20 character LCD Dot-matrix with eleven indicating lights (LED's), nine scrolling / command buttons and audible alarm which sounds whenever there is a problem.

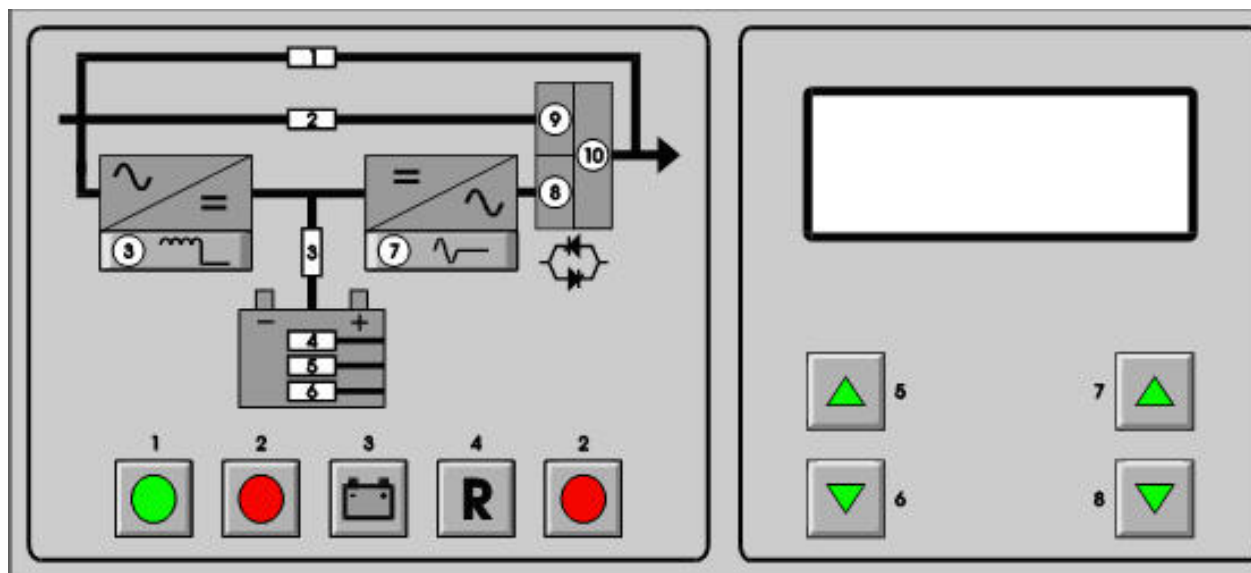

LCD Digital Meter readings (top two lines)

- **Inverter:** Volts AC / % Load / Frequency
- **Reserve:** Volts AC / Frequency
- **Charger:** Volts AC / Frequency
- **Battery / DC:** Volts DC / Battery Charge - Discharge
- **Environment:** Ambient Temperature
- **General:** Run time

LCD Scrolling Alarms / Status Text (lower two lines)

- Charger / Reserve input Mains Fail
- Phase Rotation incorrect
- Boost Charge (Ni-Cad batteries)
- Battery / DC Over-voltage
- Overload
- Short-circuit
- Over-temperature
- Inverter Under-voltage
- Inverter fault
- Load on Inverter
- Load on Reserve
- Battery Low
- Battery Under-voltage

System and Installation considerations

- **Room ventilation:** Adequate ventilation should be provided for safe dispersal of potentially explosive gases created by the batteries. The system will generate a small amount of heat during standby operation but during battery discharge and recharge a greater amount of heat will be generated, adequate ventilation is required to keep the room cool so that the battery temperature does not rise significantly.
- **Environment:** Room must be kept dry and free from dirt and dust.
- **Correct rating of system:** Luminaires should be checked for actual power consumption including the efficiency of the luminaire and then summed to determine the actual load on the system. Spare capacity should be allowed for future growth. The better the power factor of the luminaire, the more luminaires can be connected to the system. Most high frequency luminaires have almost unity power factor which make them ideal for emergency lighting.
- **Types of lighting:** Discharge lamps take a finite time to strike and are thus not suitable for passive or active standby systems due to the short break in power during a mains fail, we offer no-break systems that can be used if it is deemed necessary to use discharge lamps for emergency lighting purposes.

Optional Factory Fitted Features

Internally fitted options

- **Built in distribution:** Single, double, three or four pole output circuit breakers can be fitted internally to eliminate the need for an external distribution board.
- **RS232 Port:** For remote monitoring Software via RS232
- **SNMP Adapter:** For remote monitoring of system via LAN
- **Charger input display:** Amps / KVA / % Load
- **Fire Test input:** Forces system to go into test by supplying 24VDC to terminals provided
- **High IP rating:** Maximum IP55

Remote Mounted Options

- **RAP:** Remote alarm panel which can be connected up to 100 meters away by 4 core cable for remote monitoring of system. Consists of LED display with audible alarm and silence button.

SINE33i SI - BS EN 50171

Systems with valve regulated lead acid batteries

[Selection Table](#)

Systems have been designed and sized to make maximum use of the batteries

System Type	KVA Rating	KW Rating	Enclosure	Additional Batteries Enclosure
1 Hour Systems				
SINE33i COMPACT SI 10K 1hr	10.0	8.5	D	SD
SINE33i COMPACT SI 15K 1hr	15.0	12.75	D	SD
SINE33i COMPACT SI 20K 1hr	20.0	17.0	D	SD
SINE33i COMPACT SI 30K 1hr	30.0	25.5	D	SD
SINE33i COMPACT SI 40K 1hr	40.0	34.0	D	2 x SD
SINE33i COMPACT SI 50K 1hr	50.0	42.5	D	2 x SD
SINE33i COMPACT SI 60K 1hr	60.0	51.0	E	2 x SD
SINE33i COMPACT SI 80K 1hr	80.0	68.0	E	2 x SD
SINE33i COMPACT SI 100K 1hr	100.0	85.0	E	2 x SD
3 Hour Systems				
SINE33i COMPACT SI 10K 3hr	10.0	8.5	D	SD
SINE33i COMPACT SI 15K 3hr	15.0	12.75	D	SD
SINE33i COMPACT SI 20K 3hr	20.0	17.0	D	2 x SD
SINE33i COMPACT SI 30K 3hr	30.0	25.5	D	Stand
SINE33i COMPACT SI 40K 3hr	40.0	34.0	D	Stand
SINE33i COMPACT SI 50K 3hr	50.0	42.5	D	Stand
SINE33i COMPACT SI 60K 3hr	60.0	51.0	E	Stand
SINE33i COMPACT SI 80K 3hr	80.0	68.0	E	Stand
SINE33i COMPACT SI 100K 3hr	100.0	85.0	E	Stand

Note: 20% Overcapacity included in above table in compliance with BS EN 50171
 Load Power Factor no better than 0.85 is assumed
 Sizes subject to change without notice

Technical Data

Enclosure

- Type: Floor standing on plinth.
- Degree of protection: IP20 (IP55 available)
- Finish: Textured, epoxy/polyester powder paint, colour RAL 7032
- Cable entry: Bottom
- Terminals: DIN Rail mounted, screw clamp type

Batteries

- Type: Maintenance free VRLA (valve regulated lead acid) 10 Year design life
- Fusegear: Double pole gR to IEC 60269-1 and -4, DIN VDE 0636-23

Charger

- Mains Supply: 400VAC +/-10% Three Phase 50 or 60Hz +/-5%
- Input Protection: MCB to BS EN 60898
- Fusegear: gR to IEC 60269-1 and -4, DIN VDE 0636-23
- Charging: Constant voltage, current limited. Battery Float Voltage controlled to 1% with full mains supply variations. Full recharge within 24 hours, 80% capacity within 12 hours
- Temperature Compensation: +/-3mV/ degree C/cell
- Protections: Battery over-voltage protection, mains low protection and input surge protection
- Technology: Full wave controlled thyristor / diode bridge

Inverter

- Voltage: 380/400/415VAC (default = 400V) Three Phase, other voltages available on request
- Voltage Regulation: Static +/-1%, Dynamic +/-6%
- Voltage Waveform: Sinusoidal
- Frequency: 50 or 60Hz +/-0.1%
- Distortion (THD): <3% into linear load
- Load Power Factor: 0.3 lag to 0.3 lead
- Crest Factor: 3:1
- Overload (KVA): 120% continuous 121% for 2 minutes, 160% for 5 seconds without reduction in output voltage
- Efficiency: 90-93% depending on system
- Synchronising: Inverter synchronises with mains before Static Switch changeover
- Protections: Electronic overload / short circuit, over-temperature, inverter over/under-voltage, DC input reverse polarity, battery low voltage shutdown
- Deep discharge Protection: In accordance with BS EN 50171:2001
- Technology: High frequency, pulse width modulated IGBT with isolation transformer

Static Switch Changeover

- Type: Fully automatic transfer / retransfer capability
- Overload: 1000% for 1 cycle, 200% continuous
- Detection and transfer time: 2 mSec

General

- Noise Level: <55dBA @ 1 metre
- Maximum Relative Air Humidity: 90%, non-condensing
- Maximum Altitude: 1000m Above sea level before de-rating
- Max/Min Temperature: 0-40 Degree C
- Recommended Temperature: 20 Degree C for optimal battery life

Standards

- BS EN 50171:2001
- BS EN 50091-1 (Safety)
- BS EN 50091-2 (EMC)
- BS EN 61000-3-4 (Harmonics)