

EF20 Industrial UPS



The **EF20** series of Industrial Uninterruptible Power Supplies (UPS) provide high quality reliable power for the most critical applications. The EF20 is a True Online Double Conversion type system with a high frequency PWM inverter.

Unlike most transformer-less commercial UPS's, the EF20 has galvanic isolation between the battery and the output – this isolation prevents high voltage DC from damaging equipment connected to the UPS

Single and three phase input options are available with a single phase output.
The standard output is 230VAC 50Hz but virtually any voltage / frequency is achievable.

Manufactured in the UK

UPS Systems - Industrial UPS

System Operation

- Mains Available:** The mains power supplies the rectifier (power factor corrected) which converts the AC to DC, the rectifier then supplies the inverter with power and charges the battery, the battery is kept fully charged at float voltage ready in case the mains fails. The inverter switches the DC to AC and supplies power to the load through the static switch.
- Mains Fail:** The inverter is supplied by the battery and continues to supply power to the load in the same way as when mains is available. The inverter will produce the same high quality Sine-wave for the rated duration; once this point is reached the inverter will turn off automatically to protect the batteries.
- Mains Return:** The rectifier soft starts and then begins to charge the battery at constant current. If the mains failure was long enough to discharge the battery completely (battery U/V) then the inverter will be off and the static switch will default to bypass. A short while later the inverter will automatically restart and the static switch will transfer the load back to the inverter.
- Static Switch reserve in operation:** If the inverter is switched off (manually or by failure) or overloaded, the load is transferred automatically to the mains through the static switch (bypass). When the inverter is restarted or the overload is removed, the load is transferred back to the inverter. The transfer of the static switch (with virtually no break) is made possible by synchronising the inverter to the mains supply frequency.
- Manual bypass in operation:** The manual bypass facility is essentially a hard wire connection between the reserve supply (usually mains) and the output, its main function is to allow essential maintenance to be carried out without any break in power. To enable manual bypass the load must first be transferred to static bypass, once the manual bypass is on, the system can be turned off completely.

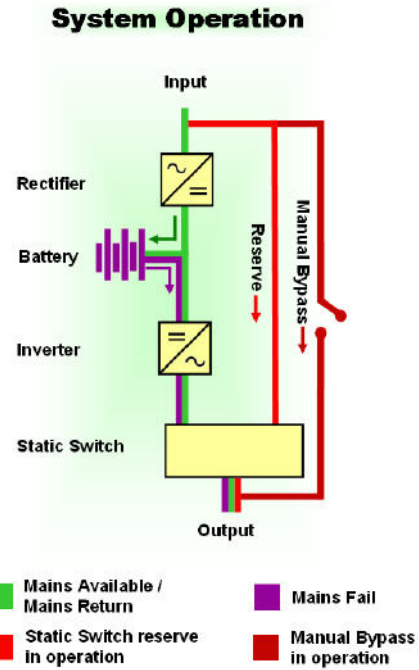

Specifications

Enclosure

- High quality steel enclosure finished in RAL7032 powder coating
- Cable entry is at the rear for NA, NB and NC enclosures and top cable entry on the SD enclosure, all systems have removable gland/back plates to allow for simple installation
- IP rating for standard enclosures is IP21 (higher IP ratings available)
- Castors are provided on systems supplied in NA, NB and NC enclosures to allow good manoeuvrability during installation. A Plinth on systems supplied in SD enclosures allows good manoeuvrability with forklift or pallet truck during installation, cabinets are sized to fit through standard doors. Plinth colour RAL7011
- The SD enclosure is supplied with a Key locked front door with the option of double key locks available for units with restricted security access

Dimensions

| Type | H | W | D |
|--|------|-----|-----|
| NA | 870 | 350 | 700 |
| NB | 870 | 450 | 850 |
| NC | 980 | 530 | 850 |
| SD | 1800 | 820 | 620 |
| Sizes subject to change without notice | | | |

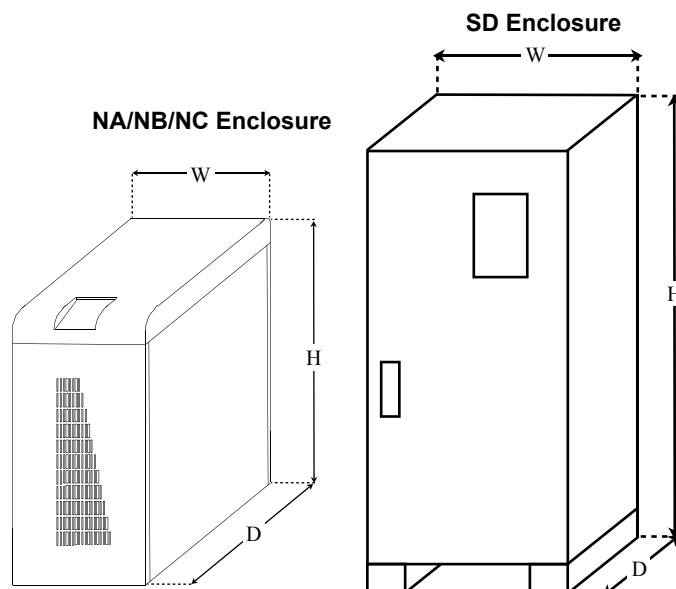

Rectifier

- Power Factor Corrected, microprocessor controlled rectifier, this means that current drawn from the mains is in phase with the voltage (0.99pF @ full load). In simple terms it means that you pay less money on your electric bill to achieve the same result as a non-power factor corrected rectifier. It also means less distortion of your mains supply and lower AC ripple into the battery which improves battery life.
- Single and three phase input available
- Full battery recharge within 24 hours, 80% capacity within 12 hours
- Constant voltage, current limited.
- Battery disconnect sensing – the microprocessor tests connection between battery and charger/inverter by monitoring the battery charge current, this monitoring proves that the battery fuse and cable are intact.
- Protection against battery over-voltage, input mains low and mains surges e.g. Surges caused by lightning.

Battery

- Valve Regulated Lead Acid (VRLA)
- 5 or 10 Year life at 20 Degrees C
- Complies with BS EN60896-2

Remote Monitoring circuits

- Common Alarm Volt free contact

Inverter

- High Frequency microprocessor controlled pulse width modulation (PWM) IGBT inverter
- High quality sinewave output
- Galvanic isolation
- High efficiency
- Reliable, proven design

Redundant Supply

- The redundant supply provides critical backup to the reserve path of the static switch in the event of total failure of the main control circuitry.

Datalogger

- 200 Alarm records and 200 Battery records accessed via the display, optional printer is available for hardcopy printout.

Manual Battery test

- A ten minute test and a deep test (30 min - 3 hrs) are accessible via the display, the system will simulate a mains failure and discharge the battery for the predetermined time, and once the test is complete the system will reset and display an alarm if the battery is faulty.

Display

- Consists of 4 x 20 character LCD Dot-matrix with fourteen indicating lights (LED's), ten scrolling / command buttons and audible alarm which sounds whenever there is a problem.

EF20 Industrial UPS

LCD Digital Meter readings (top two lines)

- **Inverter:** Volts AC / Amps / KVA / % Load / Frequency
- **Reserve:** Volts AC / Amps / KVA / % Load / Frequency
- **Rectifier:** Volts AC / Frequency
- **Battery / DC:** Volts DC / Battery Charge - Discharge Amps
- **Environment:** Ambient Temperature / Battery Temperature
- **General:** Time / Date / Auto-Test time and date of test

LCD Scrolling Alarms / Status Text (lower two lines)

- Rectifier / Reserve input Mains Fail
- Boost Charge (Ni-Cad batteries)
- Battery Disconnected
- Battery / DC Over-voltage
- Battery Test – 10 minute / Deep test
- Battery Fault – Failed Battery Test
- DC Earth leakage (option)
- Auto-Test - Automatic Battery Test
- Overload
- Short-circuit
- Over-temperature
- Inverter Under-voltage
- Inverter IGBT saturation fault
- Inverter Peak current fault
- Load on Inverter
- Load on Reserve
- Battery Low
- Battery Under-voltage
- Power Supply fault

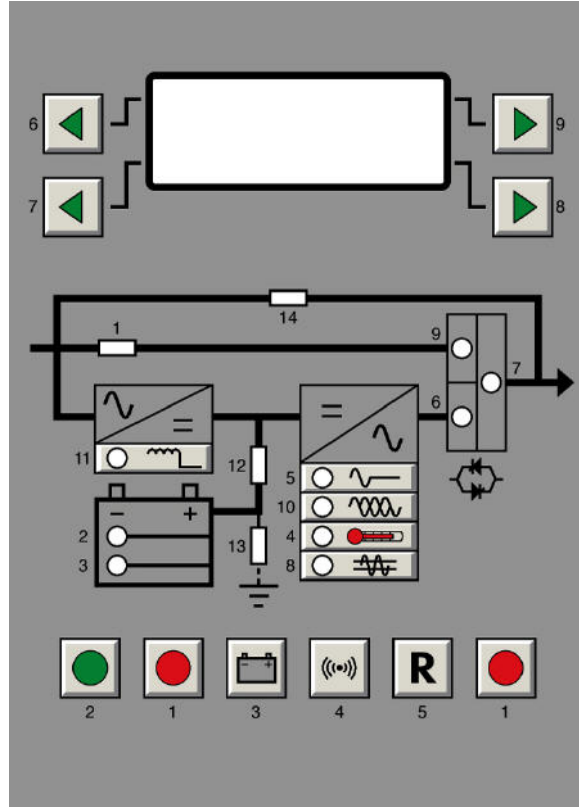

System and Installation considerations

- **Room ventilation:** Adequate ventilation should be provided for safe dispersal of potentially explosive gases created by the batteries and any heat dissipated by the unit. The amount of heat dissipated is proportional to the amount of load connected to the unit – as a guide, 100W of heat will be generated for every 1000W of load.
- **Environment:** All systems use forced cooling to extract heat from the enclosure therefore it is important that the room is kept dry and free from dirt and dust.
- **Correct rating of system:** All loads should be checked for actual power consumption and then summed to determine the actual load on the system. Spare capacity should be allowed for future growth. Some loads demand a high inrush current; air-conditioning systems, compressors and motors are some of the most common, x10 inrush currents are common with these types of loads so it is very important that these are allowed for when sizing the system

Optional Factory Fitted Features

Internally fitted options

- **Built in distribution:** Single or double pole output circuit breakers can be fitted internally to eliminate the need for an external distribution board. Maximum number of outlets is 10 for single pole and 5 for double pole
- **Printer:** A panel mount or free standing impact printer is available for hardcopy printout of Datalogger and battery test data
- **Volt Free Contacts (basic):** An extra three contacts in addition to the common alarm
- **Volt Free Contacts (full):** Ten contacts for comprehensive monitoring
- **RS232 Port:** For remote monitoring Software via RS232
- **SNMP Adapter:** For remote monitoring of system via LAN (Software included)

EF20 Industrial UPS

- **Battery Earth Leakage:** Protects system from leaking batteries and display mA reading and alarm if leakage current is too high
- **Temperature Compensation:** Battery charge voltage adjusted (+-3mV/degree C) in accordance with battery manufacturer's specification to optimise battery life
- **Low Battery Voltage Disconnect:** This circuit operates after the inverter has turned off due to a low battery shutdown and prevents the system from discharging the batteries during extended periods of mains supply failure
- **Rectifier Input Isolation:** An isolation transformer in the rectifier path, this transformer isolates the batteries from the mains supply
- **Reserve Input Isolation:** An isolation transformer in the reserve path, this transformer isolates the output from the mains supply during bypass operation
- **AC output Earth Leakage protection:** Can be set to 30/100/300mA depending on application
- **Rectifier input display:** Amps / KVA / % Load
- **High IP rating:** Maximum IP55

Remote Mounted Options

- **RAP (basic):** Remote common alarm panel which can be connected by 2 core cable for remote monitoring of system. Consists of one flashing LED with audible alarm and silence button.
- **RAP (full):** Remote alarm panel which can be connected up to 100 meters away by 4 core cable for remote monitoring of system. Consists of ten LED display with audible alarm and silence button.
- **RAP with RAR:** Same as above but with added relays for volt free monitoring.

System Ratings

| System Type | Input | Output | Watts/VA Rating | Current @ 230V | Enclosure |
|-------------|--------|--------|-----------------|----------------|-----------|
| EF20-3.2k | Single | Single | 3.2K | 13.9A | NA |
| EF20-4.8k | Single | Single | 4.8K | 20.8A | NA |
| EF20-4.8k | Three | Single | 4.8K | 20.8A | NB |
| EF20-6.4k | Single | Single | 6.4K | 27.8A | NB |
| EF20-6.4k | Three | Single | 6.4K | 27.8A | NB |
| EF20-8.0k | Single | Single | 8.0K | 34.7A | NB |
| EF20-8.0k | Three | Single | 8.0K | 34.7A | NB |
| EF20-10k | Single | Single | 10K | 43.4A | NB |
| EF20-10k | Three | Single | 10K | 43.4A | NB |
| EF20-12k | Single | Single | 12K | 52.1A | NC |
| EF20-12k | Three | Single | 12K | 52.1A | NC |
| EF20-16k | Single | Single | 16K | 69.5A | NC |
| EF20-16k | Three | Single | 16K | 69.5A | NC |
| EF20-20k | Single | Single | 20K | 86.9A | SD |
| EF20-20k | Three | Single | 20K | 86.9A | SD |
| EF20 24k | Single | Single | 24K | 104.3A | SD |
| EF20-24k | Three | Single | 24K | 104.3A | SD |
| EF20-32k | Three | Single | 32K | 139.1A | SD |

Note: Sizes subject to change without notice

All batteries housed in extensions / external racks / cabinets to suit customer needs

Technical Data

Enclosure

- **Type:** Floor standing on castors/plinth.
- **Degree of protection:** IP21/23 (IP55 available)
- **Finish:** Textured, epoxy/polyester powder paint, colour RAL 7032
- **Cable entry:** Rear/Top
- **Terminals:** DIN Rail mounted or direct into EMC filter, screw clamp type

Batteries

- **Type:** Maintenance free VRLA (valve regulated lead acid) 5 or 10 Year design life
- **Fusegear:** Double pole gR to IEC 60269-1 and -4, DIN VDE 0636-23

Rectifier – Power Factor Corrected

- **Mains Supply Voltage:** 230/400VAC +/-10% Single or Three Phase (other voltages available on request)
- **Mains Supply Frequency:** 50 or 60Hz +/-5% (other frequencies available on request)
- **Power Factor:** 0.99pF @ full load
- **Input Protection:** MCB to BS EN60898
- **Fusegear:** gR to IEC 60269-1 and -4, DIN VDE 0636-23
- **Charging:** Constant voltage, current limited. Battery Float Voltage controlled to 1% with full mains supply variations. Full recharge within 24 hours, 80% capacity within 12 hours
- **Protections:** Battery over-voltage protection, mains low protection and input surge protection
- **Technology:** Full wave controlled thyristor / diode bridge with IGBT power factor correction – micro-processor controlled

Inverter

- **Voltage:** 220/230/240VAC Single Phase (other voltages available on request)
- **Voltage Regulation:** Static +/-1%, Dynamic +/-6%
- **Voltage Waveform:** Sinusoidal
- **Frequency:** 50 or 60Hz +/-0.1% (other frequencies available)
- **Distortion (THD):** <3% into linear load
- **Load Power Factor:** 0.3 lag to 0.3 lead
- **Crest Factor:** 3:1
- **Overload (KVA):** 120% continuous 121% for 2 minutes, 160% for 5 seconds without reduction in output voltage
- **Efficiency:** 90-93% depending on system
- **Synchronising:** Inverter synchronises with mains supply (+/-0.1% Free running)
- **Protections:** Electronic overload / short circuit, over-temperature, inverter over/under-voltage, DC input reverse polarity, battery low voltage shutdown
- **Technology:** High frequency, pulse width modulated IGBT with isolation transformer

Static Switch

- **Fully automatic transfer/retransfer capability**
- **Frequency tracking and locking range:** 0.5, 1, 2 or 4% selectable
- **Total detection and transfer time:** 500 (Micro seconds)
- **Slew Rate:** 0.05, 0.1, 0.2 or 0.4 Hz/sec selectable

General

- **Noise Level:** <55dBA @ 1 metre for systems up to 16KVA, <62dBA @ 1 metre for larger systems
- **Maximum Relative Air Humidity:** 90%, non-condensing
- **Maximum Altitude:** 1000m Above sea level before de-rating

Standards

- BS EN 50091-1 (Safety)
- BS EN 50091-2 (EMC)
- BS EN 61000-3-4 (Harmonics)