

EF20 CENTRAL BATTERY - BS EN 50171



The **EF20 COMPACT SI** series of AC-DC Central Battery System fully complies with BS EN 50171:2001. The system is based on the standard EF20 range but has been specifically designed for applications where only a small amount of floor space is available. The batteries are housed in the same enclosure as the electronics on smaller models, thus keeping the overall footprint of the unit as small as possible. All components including batteries can be accessed from the front so there is no need to leave space at the back or sides of the unit for ventilation or maintenance. The units are offered with contactor changeover as standard, with optional multiple load paths. Please specify when ordering.

The systems output voltage is 48/110/220VAC during mains operation, reverting to 48/110/220VDC during mains failure.

Single and three phase input options are available with a single phase output, three phase systems have the added advantage of phase monitoring, this means if any of the incoming phases fail the unit will go into backup mode.

Systems have been designed and sized to make maximum use of the batteries; this means you get the best possible value for your money.

Manufactured in the UK

EF20 CENTRAL BATTERY - BS EN 50171

System Operation

- **Mains Available:** The mains power supplies the battery charger (power factor corrected) which converts the AC into DC and charges the battery. The mains power also supplies power to the load via the Changeover Contactor, this is the reserve or bypass path and is used with maintained systems; on systems with three phase input, the maintained circuit is supplied by one of the input phases (usually L3). The maintained power can be remotely controlled via an external switched input (option).
- **Mains Fail:** The Changeover Contactor is switched to allow DC power to the load. The unit will supply 48/110/220VDC for the rated duration, once this point is reached the inverter will turn off automatically to protect the batteries.

Specifications

Enclosure

- High quality steel enclosure finished in RAL7032 powder coating
- Front access enclosure – all parts including batteries can be replaced or measured via the front door so there is no need to leave space at the back or sides of the unit for ventilation or maintenance
- Top cable entry with removable gland plate for simple installation
- IP rating for standard enclosures is IP23 (higher IP ratings available)
- Plinth allows good manoeuvrability with forklift or pallet truck during installation, cabinets are only 600/400mm deep so fitting through standard doors is no problem. Plinth colour RAL7011
- Key locked front door with the option of a double key locks (SD enclosure) available for units with restricted security access

Dimensions

Type	H	W	D
SB(IP23)	1275	800	400
SC(IP23)	1475	800	400
SD(IP23)	1800	820	620

Sizes subject to change without notice

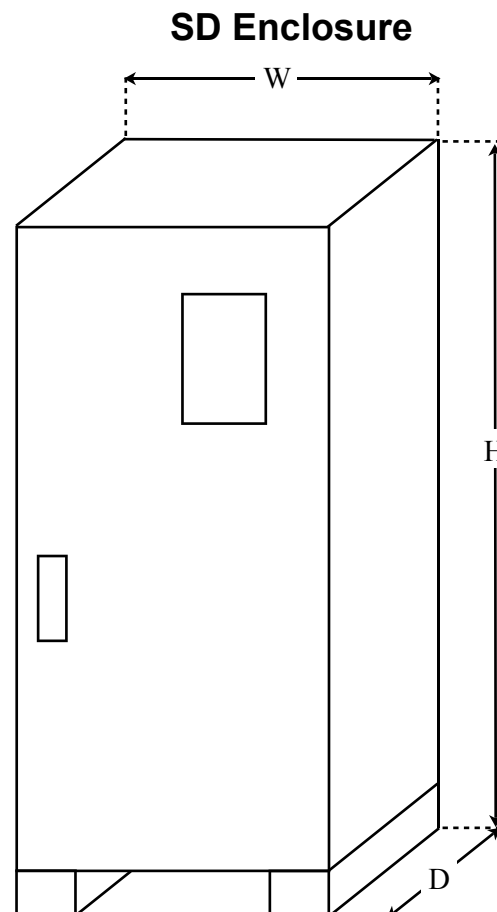
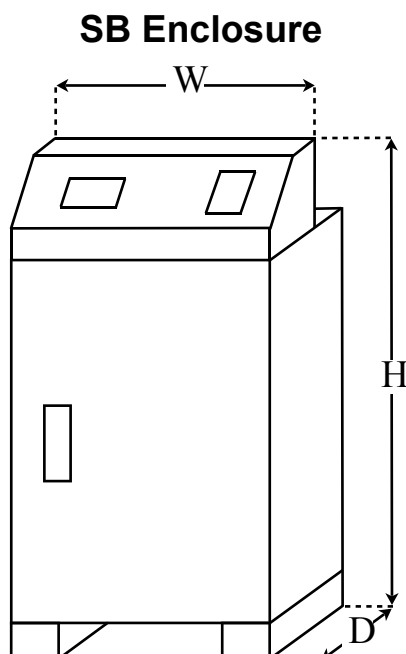

System Operation

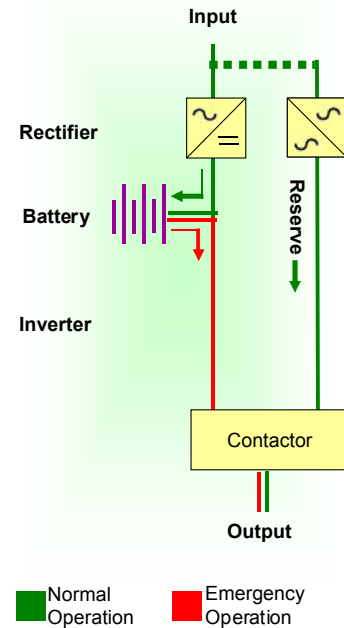

EF20 CENTRAL BATTERY - BS EN 50171

[Battery Charger](#)

- Power Factor Corrected, microprocessor controlled battery charger; this means that during battery recharge the current drawn from the mains is in phase with the voltage (0.99PF during recharge). In simple terms it means that you pay less money on your electric bill to achieve the same result as a non-power factor corrected charger. It also means less distortion of your mains supply and low AC ripple into the battery which improves battery life.
- Single and three phase input available
- Full recharge within 24 hours, 80% capacity within 12 hours in compliance with BS EN 50171:2001
- Temperature compensation – battery charge voltage adjusted (+3mV/degree C/cell) in accordance with battery manufacturers specification to optimise battery life
- Constant voltage, current limited.
- Battery disconnect sensing – the microprocessor tests connection between battery and charger/inverter by monitoring the battery charge current, this monitoring proves that the battery fuse and cable are intact.
- Protection against battery over-voltage, input mains low and mains surges e.g. Surges caused by lightning.

[Battery](#)

- Valve Regulated Lead Acid (VRLA)
- 10 Year life at 20 Degrees C
- Complies with BS EN 60896-2

[Changeover contactor](#)

- Four pole - 2 normally open and two normally closed, both the live and neutral are switched
- Complies with relevant standards of BS 5424

[Load circuit](#)

- Single output load circuit - selectable maintained/non-maintained by changing jumper bar on input terminals (default maintained)
- Multiple output distribution option available

[Remote Monitoring circuits](#)

- Volt free contacts (basic) - Common Alarm, Mains Fail, Battery Low, Overload

[Low Battery Voltage Disconnect](#)

- This circuit operates after the inverter has turned off due to a low battery shutdown and prevents the system from discharging the batteries during extended periods of mains supply failure.

[Datalogger](#)

- 200 Alarm records and 200 Battery records accessed via the display, optional printer is available for hardcopy printout.

[Manual Battery test](#)

- A ten minute test and a deep test (30 min - 3 hrs) are accessible via the display, the system will simulate a mains failure and discharge the battery for the predetermined time, and once the test is complete the system will reset and display an alarm if the battery is faulty.

[Auto Battery test](#)

- A monthly ten minute battery test can be activated. During setup a convenient time and day for the test can be set. The battery capacity is tested, and once the test is complete the system will reset and display an alarm if the battery is faulty.

EF20 CENTRAL BATTERY - BS EN 50171

Display

- Consists of 4 x 20 character LCD Dot-matrix with fourteen indicating lights (LED's), ten scrolling / command buttons and audible alarm which sounds whenever there is a problem.

LCD Digital Meter readings (top two lines)

- **Reserve:** Volts AC / Amps / KVA / % Load / Frequency
- **Charger:** Volts AC / Frequency
- **Battery / DC:** Volts DC / Battery Charge - Discharge Amps
- **Environment:** Ambient Temperature / Battery Temperature
- **General:** Time / Date / Auto-Test time and date of test

LCD Scrolling Alarms / Status Text (lower two lines)

- Charger / Reserve input Mains Fail
- Boost Charge (Ni-Cad batteries)
- Battery Disconnected
- Battery / DC Over-voltage
- Battery Test – 10 minute / Deep test
- Battery Fault – Failed Battery Test
- DC Earth leakage (option)
- Auto-Test - Automatic Battery Test
- Overload
- Short-circuit
- Over-temperature
- Battery Low
- Battery Under-voltage
- Power Supply fault

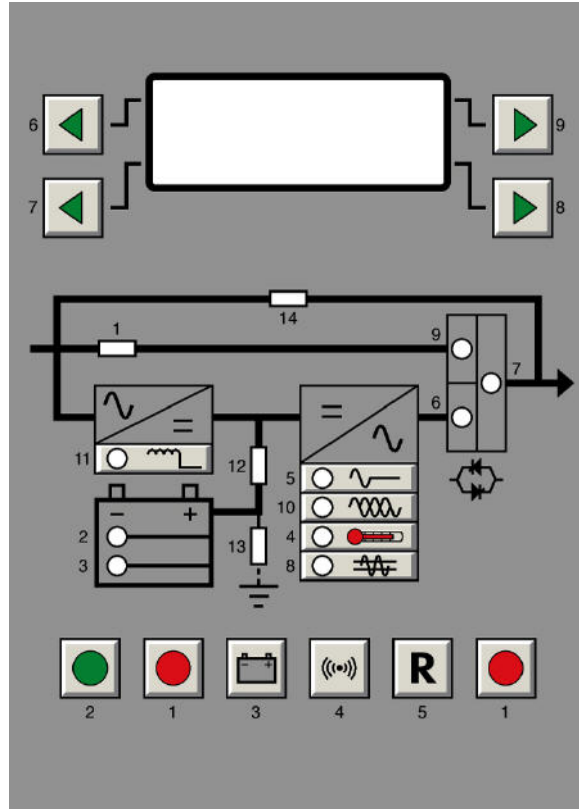

System and Installation considerations

- **Room ventilation:** Adequate ventilation should be provided for safe dispersal of potentially explosive gases created by the batteries. The system will generate a small amount of heat during standby operation but during battery discharge and recharge a greater amount of heat will be generated, adequate ventilation is required to keep the room cool so that the battery temperature does not rise significantly.
- **Environment:** Room must be kept dry and free from dirt and dust.

Optional Factory Fitted Features

Internally fitted options

- **Built in distribution:** Single or double pole output circuit breakers can be fitted internally to eliminate the need for an external distribution board. Maximum number of outlets is 10 for single pole and 5 for double pole
- **Printer:** An impact printer is available for hardcopy printout of Datalogger and battery test data
- **Volt Free Contacts (full):** Ten contacts for comprehensive monitoring
- **RS232 Port:** For remote monitoring Software via RS232
- **SNMP Adapter:** For remote monitoring of system via LAN
- **Battery Earth Leakage:** Protects system from leaking batteries and display mA reading and alarm if leakage current is too high
- **Switched Maintained Control:** The maintained power can be remotely controlled via an external switch
- **Three phase monitoring:** Detects a phase failure, causing either the non-maintained output to switch to maintained or the inverter to start and power the load (selectable depending on circumstances)
- **Charger input display:** Amps / KVA / % Load

EF20 CENTRAL BATTERY - BS EN 50171

- **Fire Test input:** Forces system to go into test by supplying 24VDC to terminals provided
- **High IP rating:** Maximum IP54

Remote Mounted Options

- **RAP (basic):** Remote common alarm panel which can be connected by 2 core cable for remote monitoring of system. Consists of one flashing LED with audible alarm and silence button.
- **RAP (full):** Remote alarm panel which can be connected up to 100 meters away by 4 core cable for remote monitoring of system. Consists of ten LED display with audible alarm and silence button.
- **RAP with RAR:** Same as above but with added relays for volt free monitoring as well.

EF20 CENTRAL BATTERY - BS EN 50171

Systems with valve regulated lead acid batteries

[Selection Table](#)

Systems have been designed and sized to make maximum use of the batteries
Three phase input available on units 12KVA and larger - specify input when ordering

System Type	KVA Rating	KW Rating	Enclosure	Additional Batteries Enclosure
1 Hour Systems				
EF20 CENTRAL BATTERY 2.0K 1hr	2.0	1.7	SB	X
EF20 CENTRAL BATTERY 2.5K 1hr	2.5	2.1	SB	X
EF20 CENTRAL BATTERY 3.2K 1hr	3.2	2.7	SC	X
EF20 CENTRAL BATTERY 4.8K 1hr	4.8	4.1	SC	X
EF20 CENTRAL BATTERY 6.0K 1hr	6.0	5.1	SD	X
EF20 CENTRAL BATTERY 8.0K 1hr	8.0	6.8	SD	X
CENTRAL BATTERY 10.0K 1hr	10.0	8.5	SD	X
EF20 CENTRAL BATTERY 12.0K 1hr	12.0	10.2	SD	SD
EF20 CENTRAL BATTERY 14.0K 1hr	14.0	11.9	SD	SD
EF20 CENTRAL BATTERY 16.0K 1hr	16.0	13.6	SD	SD
EF20 CENTRAL BATTERY 20.0K 1hr	20.0	17.0	SD	2 x SD
EF20 CENTRAL BATTERY 24.0K 1hr	24.0	20.4	SD	2 x SD
EF20 CENTRAL BATTERY 30.0K 1hr (3 Phase input only)	32.0	27.2	SD	2 x SD
3 Hour Systems				
CENTRAL BATTERY 1.0K 3hr	1.0	0.85	SB	X
CENTRAL BATTERY 2.0K 3hr	2.0	1.7	SC	X
EF20 CENTRAL BATTERY 2.5K 3hr	2.5	2.1	SC	X
EF20 CENTRAL BATTERY 3.2K 3hr	3.2	2.7	SD	X
CENTRAL BATTERY 4.8K 3hr	4.8	4.1	SD	X
EF20 CENTRAL BATTERY 5.6K 3hr	5.6	4.8	SD	X
EF20 CENTRAL BATTERY 6.0K 3hr	6.0	5.1	SD	X
EF20 CENTRAL BATTERY 8.0K 3hr	8.0	6.8	SD	X
CENTRAL BATTERY 10.0K 3hr	10.0	8.5	SD	SD
EF20 CENTRAL BATTERY 12.0K 3hr	12.0	10.2	SD	SD
EF20 CENTRAL BATTERY 14.0K 3hr	14.0	11.9	SD	2 x SD
EF20 CENTRAL BATTERY 16.0K 3hr	16.0	13.6	SD	3 x SD
EF20 CENTRAL BATTERY 20.0K 3hr	20.0	17.0	SD	3 x SD
EF20 CENTRAL BATTERY 24.0K 3hr	24.0	20.4	SD	3 x SD
EF20 CENTRAL BATTERY 30.0K 3hr (3 Phase input only)	32.0	27.2	SD	4 X SD

Note: 20% Overcapacity included in above table in compliance with BS EN 50171
Sizes subject to change without notice

EF20 CENTRAL BATTERY - BS EN 50171

Technical Data

Enclosure

- **Type:** Floor standing on plinth.
- **Degree of protection:** IP23 (IP55 available)
- **Finish:** Textured, epoxy/polyester powder paint, colour RAL 7032
- **Cable entry:** Top
- **Terminals:** DIN Rail mounted, screw clamp type

Batteries

- **Type:** Maintenance free VRLA (valve regulated lead acid) 10 Year design life
- **Fusegear:** Double pole gR to IEC 60269-1 and -4, DIN VDE 0636-23

Charger – Power Factor Corrected

- **Mains Supply:** 230/400VAC +/-10% Single or Three Phase 50 or 60Hz +/-5%
- **Power Factor:** 0.99pF During recharge
- **Input Protection:** MCB to BS EN 60898
- **Fusegear:** gR to IEC 60269-1 and -4, DIN VDE 0636-23
- **Charging:** Constant voltage, current limited. Battery Float Voltage controlled to 1% with full mains supply variations. Full recharge within 24 hours, 80% capacity within 12 hours
- **Temperature Compensation:** +/-3mV/ degree C/cell
- **Protections:** Battery over-voltage protection, mains low protection and input surge protection
- **Technology:** Full wave controlled thyristor / diode bridge with IGBT power factor correction – micro-processor controlled

Changeover Contactor

- **Standard:** To the relevant requirements of BS 5424

General

- **Noise Level:** <55dBA @ 1 metre
- **Maximum Relative Air Humidity:** 90%, non-condensing
- **Maximum Altitude:** 1000m Above sea level before de-rating
- **Max/Min Temperature:** 0-40 Degree C
- **Recommended Temperature:** 20 Degree C for optimal battery life

Standards

- BS EN 50171:2001
- BS EN 50091-1 (Safety)
- BS EN 50091-2 (EMC)
- BS EN 61000-3-4 (Harmonics)